

# CMO-6S3

Low power 32.768 kHz MEMS  
CMOS Clock Oscillator

QuartzCom  
the communications company

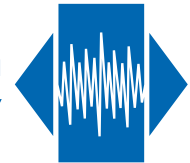

## Features

- Applications: Wi-Fi, wake-up, sleep-mode, RTC clock
- Low power consumption 7  $\mu$ A Max. / 3.3 V
- Frequency 32.768 kHz
- Sub miniature package: 2.5 x 2.0 x 1.0 mm
- High shock and vibrational resistivity

Parameter	Specification	
Frequency stability	$\leq \pm 500$ ppm	All inclusive
All inclusive frequency stability vs. temperature, tolerance @ +25 °C, aging, supply & load variation		
Supply voltage	+3.3 V	$\pm 5$ %
Current consumption	< 7 $\mu$ A	5 $\mu$ A typ.
Output signal	CMOS	
Output level	$V_{OH} > 0.9$ Vdc	$V_{OL} < 0.1$ Vdc
Output Load	15 pF	
Symmetry (Duty)	45 ~ 55 %	@ $\frac{1}{2}$ Vdc
Rise / Fall time:	< 5 ns	
Start-up time	< 50 $\mu$ s	@ 25 °C
Tri-state function	pin #1 = high or open pin #1 = low	pin #3 $\rightarrow$ signal pin #3 $\rightarrow$ high impedance
Operating temperature range	-20 ~ +70 °C	
Operable temperature range	-40 ~ +85 °C	
Storage temperature range	-55 ~ +125 °C	
Packaging units	tape & reel tape only	1'000 or 3'000pieces < 1'000 pieces

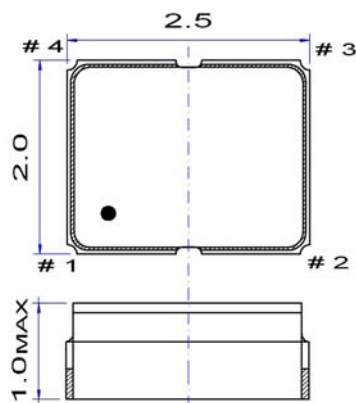

## Pin function

- # 1 Tri-state
- # 2 GND
- # 3 OUTPUT
- # 4 Vdc

## Example for solder pattern

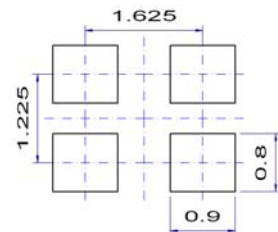

**Do not design any conductive path between the pattern**

## Example for IR reflow soldering temperature

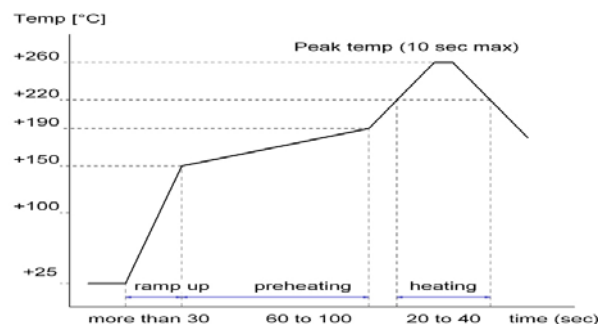

2002/95/EC RoHS compliant

QuartzCom AG  
sales@quartzcom.com

QuartzCom Asia  
sales-asia@quartzcom.com

QuartzCom USA  
sales-usa@quartzcom.com

[www.quartzcom.com](http://www.quartzcom.com)

27 May. 11

ISO 9001  
BUREAU VERITAS  
Certification

